

# Eco-Efficiency and Sustainability Performance in the Phosphate Fertilizer Industry: The Mediating Role of Technological Adoption

## Prof. Anurag Mehta

Professor,  
Faculty of Commerce and Management,  
Pacific Academy of Higher Education  
and Research University, Udaipur, Rajasthan  
ORCID ID: 0009-0005-8374-2847

## Pankaj Ostwal

Ph.D. Research Scholar,  
Faculty of Commerce and Management,  
Pacific Academy of Higher Education  
and Research University, Udaipur, Rajasthan  
ORCID ID: 0009-0005-8374-2847

## Prof. Hemant Kothari

President,  
Pacific Academy of Higher Education  
and Research University, Udaipur, Rajasthan  
kots.hemant@gmail.com  
ORCID ID: 0000-0001-9771-0575  
Corresponding Author

## Dr. Surya Prakash Vaishnav

Associate Professor,  
Faculty of Commerce and Management,  
Pacific Academy of Higher Education  
and Research University, Udaipur, Rajasthan  
suryapacific2525@gmail.com  
WoS ID: KIE-3549-2024  
ORCID ID: 0009-0006-4686-384X

## Abstract

The growing emphasis on sustainable industrial development has increased the need for industries to balance economic performance with environmental and social responsibilities. Among resource-intensive sectors, the phosphate fertilizer industry faces significant sustainability challenges due to high energy consumption, waste generation, emissions, and dependence on non-renewable resources. In response to these challenges, eco-efficiency has emerged as an important operational approach for improving resource utilization and reducing environmental impact while maintaining productivity and competitiveness. Despite increasing interest in industrial sustainability, limited empirical research has examined the relationship between eco-efficiency practices and sustainability performance within the phosphate fertilizer industry.

The present study examines the impact of eco-efficiency practices on sustainability performance, with particular emphasis on the mediating role of technological adoption. Eco-efficiency is conceptualized through four operational dimensions: process optimization, waste management, energy efficiency, and sustainable sourcing. Sustainability performance is examined across environmental, economic, and social dimensions based on the Triple Bottom Line framework. The study adopts a quantitative research design and collects data from 296 respondents associated with phosphate fertilizer manufacturing organizations. Structural Equation Modeling (SEM) is employed to test the proposed relationships and mediation effects.

The findings reveal that eco-efficiency practices significantly influence sustainability performance both directly and indirectly through technological adoption. Among the operational dimensions, energy efficiency demonstrates the strongest positive influence on economic and environmental performance, while sustainable sourcing significantly contributes to social performance. Technological adoption shows significant positive effects on all dimensions of sustainability performance and partially mediates the relationship between eco-

efficiency practices and sustainability outcomes. The results indicate that organizations integrating operational eco-efficiency with technological capability achieve stronger sustainability performance.

The study contributes to sustainability and industrial management literature by providing an integrated framework linking eco-efficiency, technological adoption, and sustainability performance within a resource-intensive industrial context. The findings offer important implications for managers, policymakers, and industry practitioners seeking to promote sustainable and technology-enabled production systems in the fertilizer sector.

**Keywords:** Eco-efficiency; Sustainability Performance; Technological Adoption; Phosphate Fertilizer Industry; Structural Equation Modeling (SEM); Triple Bottom Line; Energy Efficiency; Sustainable Operations.

## Introduction

Industrial sustainability has become a strategic priority for organizations operating in resource-intensive sectors. Increasing environmental concerns, regulatory pressures, and resource scarcity have compelled industries to adopt production systems that balance economic growth with environmental and social responsibility. In this context, the fertilizer industry has received growing attention because of its significant contribution to agricultural productivity as well as its environmental impact.

The phosphate fertilizer industry plays an important role in supporting global food security by improving soil fertility and crop productivity. However, phosphate fertilizer production is associated with high energy consumption, industrial emissions, wastewater generation, and waste by-products such as phosphogypsum. These environmental challenges, combined with rising operational costs and stricter sustainability regulations, have increased pressure on fertilizer manufacturers to improve operational efficiency and adopt more sustainable production practices.

Eco-efficiency has emerged as an important approach for improving industrial sustainability. The concept focuses on reducing environmental impact while simultaneously enhancing operational and economic performance

(DeSimone & Popoff, 1997). Eco-efficiency practices such as process optimization, waste management, energy efficiency, and sustainable sourcing help organizations improve resource utilization, reduce waste generation, and strengthen sustainability performance. Previous studies suggest that eco-efficiency contributes positively to environmental and operational outcomes, particularly in manufacturing and process industries (Schaltegger & Burritt, 2017).

At the same time, technological advancement has significantly transformed industrial operations. The adoption of automation systems, digital monitoring technologies, predictive analytics, and Industry 4.0 applications has improved the ability of firms to optimize production processes and manage sustainability challenges more effectively. Existing literature increasingly recognizes technological adoption as an important enabler of sustainability performance (Porter & van der Linde, 1995). However, limited empirical research has examined the mediating role of technological adoption in strengthening the relationship between eco-efficiency practices and sustainability performance, particularly within the phosphate fertilizer industry.

The present study addresses this gap by examining the impact of eco-efficiency practices on sustainability performance through the mediating role of technological adoption. The study conceptualizes eco-efficiency through four operational dimensions: process optimization, waste management, energy efficiency, and sustainable sourcing. Sustainability performance is examined across environmental, economic, and social dimensions based on the Triple Bottom Line framework. By integrating eco-efficiency, technological capability, and sustainability performance into a unified framework, the study contributes to sustainability and industrial management literature while offering practical insights for fertilizer manufacturers and policymakers.

## Literature Review and Hypothesis Development

### Eco-Efficiency and Industrial Sustainability

The concept of eco-efficiency emerged as industries

increasingly recognized the need to balance economic growth with environmental responsibility. The World Business Council for Sustainable Development defined eco-efficiency as the delivery of competitively priced goods and services while progressively reducing ecological impact and resource intensity (WBCSD, 2000). The concept promotes the idea of “doing more with less” by improving operational efficiency and reducing environmental burden simultaneously.

Unlike traditional environmental management approaches that focus mainly on pollution control and regulatory compliance, eco-efficiency emphasizes preventive and efficiency-oriented strategies. Previous research suggests that eco-efficiency contributes to both environmental and economic performance by reducing resource consumption, waste generation, and operational inefficiencies (DeSimone & Popoff, 1997).

Industrial sustainability literature identifies eco-efficiency as an important operational capability that enables firms to improve competitiveness while addressing sustainability concerns. Hart (1995) argued that environmentally oriented operational capabilities may become important strategic resources that contribute to long-term competitive advantage. Similarly, Porter and van der Linde (1995) suggested that environmental improvement and economic performance are not necessarily conflicting objectives and that sustainability-oriented innovations may enhance productivity and competitiveness.

In industrial sectors such as fertilizer manufacturing, eco-efficiency is particularly important because production processes are resource-intensive and environmentally sensitive. Fertilizer production involves significant energy consumption, emissions, and waste generation, increasing the importance of sustainable operational practices.

The present study conceptualizes eco-efficiency through four operational dimensions:

- process optimization,
- waste management,
- energy efficiency,
- and sustainable sourcing.

These dimensions are expected to influence sustainability

performance directly and indirectly through technological adoption.

### **Technological Adoption and Sustainability Performance**

Technological adoption has become a major driver of industrial sustainability in recent years. The integration of automation, digital systems, analytics, and Industry 4.0 technologies has significantly transformed industrial operations. Technologies such as smart monitoring systems, predictive maintenance, process automation, and digital energy management systems improve operational efficiency and resource utilization.

The Resource-Based View (RBV) suggests that technological capability functions as a strategic organizational resource that enhances performance and competitiveness (Barney, 1991). Organizations possessing advanced technological capabilities are often better positioned to optimize operational processes and improve sustainability outcomes.

Several studies have highlighted the role of technology in improving:

- environmental management,
- operational control,
- energy efficiency,
- and waste reduction.

Melnyk et al. (2003) observed that environmental management systems supported by technological infrastructure contribute positively to operational and environmental performance. Similarly, Shrivastava (1995) emphasized that environmental technologies can generate competitive advantage through improved efficiency and sustainability.

Within sustainability research, technological adoption is increasingly viewed as an enabling mechanism that strengthens the effectiveness of eco-efficiency practices. Firms implementing eco-efficient practices often rely on technological systems for:

- process monitoring,
- waste recovery,
- energy optimization,
- and operational control.

Accordingly, technological adoption is expected to mediate the relationship between eco-efficiency practices and sustainability performance.

### **Sustainability Performance and the Triple Bottom Line Framework**

The concept of sustainability performance has expanded beyond traditional financial performance to include environmental and social dimensions. The Triple Bottom Line (TBL) framework proposed by Elkington (1997) emphasizes that organizations should achieve balance across:

- environmental performance,
- economic performance,
- and social performance.

#### **Environmental Performance**

Environmental performance relates to reducing ecological impact through lower emissions, efficient resource utilization, pollution control, and waste reduction.

#### **Economic Performance**

Economic performance includes operational efficiency, productivity improvement, cost reduction, and profitability enhancement.

#### **Social Performance**

Social performance reflects organizational responsibility toward employees, stakeholders, communities, and ethical practices.

The literature suggests that sustainability performance is multidimensional and influenced by operational capabilities, innovation, and technological systems. However, many prior studies focus primarily on environmental outcomes while giving comparatively limited attention to integrated sustainability performance.

The present study adopts the TBL framework to examine sustainability performance comprehensively across environmental, economic, and social dimensions.

### **Hypothesis Development**

#### **Process Optimization and Technological Adoption**

Process optimization focuses on improving operational efficiency through better workflow design, reduction of

inefficiencies, and effective resource utilization. Modern process optimization increasingly depends on digital systems, automation, and process monitoring technologies. Organizations emphasizing operational optimization are therefore more likely to adopt advanced technological systems to improve process control and efficiency.

**H1:** Process optimization has a significant positive effect on technological adoption.

#### **Waste Management and Technological Adoption**

Effective waste management in industrial production requires technologies related to recycling, waste recovery, emission control, and monitoring systems. Previous studies suggest that organizations focusing on waste reduction often adopt technological solutions to improve environmental management and operational sustainability.

**H2:** Waste management has a significant positive effect on technological adoption.

#### **Energy Efficiency and Technological Adoption**

Energy efficiency is strongly associated with technological systems such as automation, smart energy management, predictive maintenance, and digital monitoring systems. Firms seeking to improve energy utilization are likely to adopt advanced technologies to optimize operational performance.

**H3:** Energy efficiency has a significant positive effect on technological adoption.

#### **Sustainable Sourcing and Technological Adoption**

Sustainable sourcing practices increasingly depend on digital procurement systems, supplier monitoring platforms, and traceability technologies. Organizations emphasizing responsible sourcing are therefore expected to adopt technological systems that improve supply chain transparency and sustainability.

**H4:** Sustainable sourcing has a significant positive effect on technological adoption.

#### **Technological Adoption and Sustainability Performance**

Technological systems improve operational efficiency, environmental monitoring, energy management, and process control. Previous studies suggest that technological

adoption contributes positively to environmental, economic, and social performance.

**H5a:** Technological adoption has a significant positive effect on environmental performance.

**H5b:** Technological adoption has a significant positive effect on economic performance.

**H5c:** Technological adoption has a significant positive effect on social performance.

### **Eco-Efficiency and Sustainability Performance**

#### **Process Optimization and Environmental Performance**

Process optimization reduces material wastage, process losses, and operational inefficiencies, thereby improving environmental outcomes.

**H6a:** Process optimization has a significant positive effect on environmental performance.

#### **Waste Management and Environmental Performance**

Waste management practices reduce pollution and improve environmental sustainability through recycling and proper disposal systems.

**H6b:** Waste management has a significant positive effect on environmental performance.

#### **Energy Efficiency and Sustainability Performance**

Energy efficiency contributes to lower energy consumption, reduced emissions, and improved operational cost efficiency.

**H6c:** Energy efficiency has a significant positive effect on environmental performance.

**H6d:** Energy efficiency has a significant positive effect on economic performance.

#### **Sustainable Sourcing and Social Performance**

Sustainable sourcing strengthens ethical procurement practices, stakeholder trust, and responsible supply chain management.

**H6e:** Sustainable sourcing has a significant positive effect on social performance.

#### **Mediating Role of Technological Adoption**

Technological adoption is expected to function as an enabling mechanism that strengthens the relationship

between eco-efficiency practices and sustainability performance. Eco-efficiency initiatives often require technological systems for effective implementation, monitoring, and optimization. Therefore, technological capability is likely to enhance the effectiveness of operational sustainability practices.

Accordingly, the study proposes the following mediation hypotheses:

**H7a:** Technological adoption mediates the relationship between eco-efficiency practices and environmental performance.

**H7b:** Technological adoption mediates the relationship between eco-efficiency practices and economic performance.

**H7c:** Technological adoption mediates the relationship between eco-efficiency practices and social performance.

### **Research Methodology**

The study adopts a quantitative research design to examine the relationship between eco-efficiency practices, technological adoption, and sustainability performance in the phosphate fertilizer industry. Data were collected through a structured questionnaire from professionals associated with fertilizer manufacturing organizations, including respondents involved in operations, production, sustainability management, procurement, and technological systems. The study follows a descriptive and explanatory research approach to analyze the relationships among the proposed constructs.

A non-probability purposive sampling technique was used for data collection. The final sample consisted of 296 valid responses. The questionnaire items were adapted from existing literature and measured using a five-point Likert scale. The major constructs included in the study were process optimization, waste management, energy efficiency, sustainable sourcing, technological adoption, and sustainability performance comprising environmental, economic, and social dimensions.

The collected data were analyzed using SPSS and AMOS software. Reliability and validity of the constructs were assessed through Cronbach's alpha, Composite Reliability (CR), and Average Variance Extracted (AVE). The study

employed Exploratory Factor Analysis (EFA), Confirmatory Factor Analysis (CFA), and Structural Equation Modeling (SEM) to test the proposed hypotheses and mediation relationships. Bootstrapping techniques were also used to examine the mediating role of technological adoption.

**Results and Analysis**

**Demographic Profile of Respondents**

A total of 296 valid responses were used for final analysis.

The respondents included professionals associated with phosphate fertilizer manufacturing organizations and related operational functions. The demographic profile indicated that the majority of respondents possessed relevant industrial and managerial exposure, thereby ensuring the reliability and contextual relevance of the responses.

**Table 1: Demographic Profile of Respondents**

Demographic Variable	Category	Frequency	Percentage
Gender	Male	214	72.3
	Female	82	27.7
Age	Below 30 years	58	19.6
	31–40 years	124	41.9
	41–50 years	79	26.7
	Above 50 years	35	11.8
Experience	Below 5 years	52	17.6
	5–10 years	108	36.5
	11–15 years	79	26.7
	Above 15 years	57	19.2
Functional Area	Operations/Production	118	39.9
	Sustainability/Environment	54	18.2
	Procurement/Supply Chain	48	16.2
	Technical/Engineering	46	15.5
	Others	30	10.2

The demographic distribution suggests that most respondents belonged to operational and technical functions, which is appropriate considering the study's focus on eco-efficiency and sustainability practices.

**Descriptive Statistics**

Descriptive statistics were computed to examine the central

tendency and dispersion of the study variables. The results indicated moderate to high mean values across all constructs, suggesting positive perceptions toward eco-efficiency practices and sustainability initiatives within the fertilizer industry.

**Table 2: Descriptive Statistics of Study Variables**

Construct	Mean	Standard Deviation
Process Optimization (PO)	4.01	0.62
Waste Management (WM)	3.94	0.66
Energy Efficiency (EE)	4.08	0.58
Sustainable Sourcing (SS)	3.89	0.71
Technological Adoption (TA)	4.03	0.60
Environmental Performance (ENV)	4.10	0.57
Economic Performance (ECO)	4.05	0.61
Social Performance (SOC)	3.96	0.65

The results indicate that energy efficiency and environmental performance reported the highest mean values, reflecting growing organizational emphasis on operational efficiency and sustainability.

### Reliability Analysis

Reliability analysis was conducted using Cronbach's alpha and Composite Reliability (CR) to assess internal consistency among the measurement items. The results indicated strong reliability across all constructs, as all values exceeded the recommended threshold of 0.70 (Hair et al., 2019).

**Table 3: Reliability and Validity Assessment**

Construct	Cronbach's Alpha	Composite Reliability (CR)	AVE
Process Optimization (PO)	0.887	0.902	0.649
Waste Management (WM)	0.871	0.894	0.633
Energy Efficiency (EE)	0.901	0.918	0.691
Sustainable Sourcing (SS)	0.864	0.889	0.615
Technological Adoption (TA)	0.912	0.926	0.704
Environmental Performance (ENV)	0.898	0.915	0.683
Economic Performance (ECO)	0.884	0.901	0.646
Social Performance (SOC)	0.876	0.896	0.632

The Average Variance Extracted (AVE) values for all constructs exceeded 0.50, thereby establishing convergent validity.

### Exploratory Factor Analysis (EFA)

Exploratory Factor Analysis (EFA) was conducted using Principal Component Analysis with Varimax rotation to examine the factor structure of the measurement items. The Kaiser-Meyer-Olkin (KMO) value and Bartlett's Test of Sphericity confirmed the adequacy of the sample and suitability of the data for factor analysis.

**Table 4: KMO and Bartlett's Test**

Measure	Value
KMO Measure of Sampling Adequacy	0.912
Bartlett's Test Approx. Chi -Square	4218.357
Degrees of Freedom	406
Significance	0.000

The KMO value exceeded the recommended threshold of 0.70, while Bartlett's Test was significant at  $p < 0.001$ , confirming factorability of the data.

The rotated component matrix indicated strong factor loadings for all items, with loadings above 0.70 and minimal cross-loadings.

**Table 5: Summary of Factor Loadings**

Construct	Factor Loading Range
Process Optimization	0.731 – 0.864
Waste Management	0.718 – 0.851
Energy Efficiency	0.754 – 0.889
Sustainable Sourcing	0.706 – 0.842
Technological Adoption	0.768 – 0.901
Environmental Performance	0.742 – 0.876
Economic Performance	0.715 – 0.858
Social Performance	0.724 – 0.847

The EFA results confirmed satisfactory construct structure and dimensionality.

**Confirmatory Factor Analysis (CFA)**

Confirmatory Factor Analysis (CFA) was conducted using AMOS to validate the measurement model. The CFA results indicated acceptable model fit based on recommended fit indices.

**Table 6: Measurement Model Fit Indices**

Fit Index	Recommended Value	Obtained Value
Chi-square/df	< 3.0	2.184
GFI	> 0.90	0.918
AGFI	> 0.80	0.891
CFI	> 0.90	0.947
TLI	> 0.90	0.939
RMSEA	< 0.08	0.063
SRMR	< 0.08	0.052

The fit indices demonstrated good model adequacy, thereby confirming the validity of the measurement model.

**Structural Equation Modeling (SEM)**

Structural Equation Modeling (SEM) was employed to examine the direct and indirect relationships among eco-efficiency dimensions, technological adoption, and sustainability performance.

The structural model demonstrated acceptable fit indices, indicating suitability of the proposed framework.

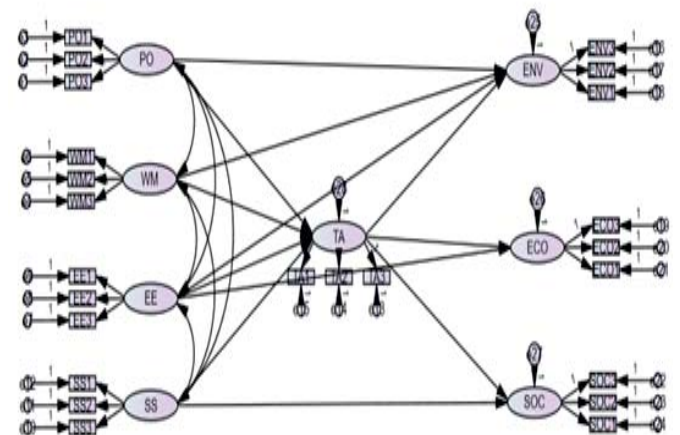
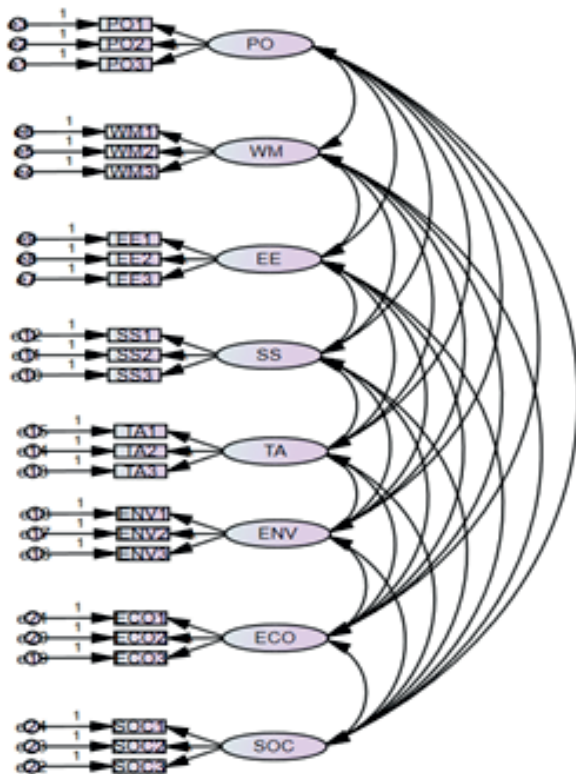

**Table 7: Structural Model Fit Indices**

Fit Index	Obtained Value
Chi-square/df	2.296
CFI	0.942
TLI	0.934
RMSEA	0.066
SRMR	0.055

### Hypothesis Testing

The standardized regression estimates were examined to test the proposed hypotheses.

**Table 8: Hypothesis Testing Results**

Hypothesis	Relationship	Standardized Estimate	p-value	Result
H1	PO → TA	0.281	0.000	Supported
H2	WM → TA	0.243	0.001	Supported
H3	EE → TA	0.392	0.000	Supported
H4	SS → TA	0.216	0.003	Supported
H5a	TA → ENV	0.447	0.000	Supported
H5b	TA → ECO	0.381	0.000	Supported
H5c	TA → SOC	0.468	0.000	Supported
H6a	PO → ENV	0.214	0.002	Supported
H6b	WM → ENV	0.248	0.001	Supported
H6c	EE → ENV	0.336	0.000	Supported
H6d	EE → ECO	0.421	0.000	Supported
H6e	SS → SOC	0.358	0.000	Supported

The results revealed that all proposed direct relationships were statistically significant. Among the eco-efficiency dimensions, energy efficiency demonstrated the strongest impact on both technological adoption and economic performance.

### Mediation Analysis

Bootstrapping analysis was conducted to examine the mediating role of technological adoption in the relationship between eco-efficiency practices and sustainability performance.

**Table 9: Mediation Analysis Results**

Mediation Path	Indirect Effect	p-value	Mediation Type
Eco-Efficiency → TA → ENV	0.241	0.000	Partial Mediation
Eco-Efficiency → TA → ECO	0.198	0.001	Partial Mediation
Eco-Efficiency → TA → SOC	0.267	0.000	Partial Mediation

The mediation analysis confirmed that technological adoption significantly mediated the relationship between eco-efficiency practices and sustainability performance. Since both direct and indirect effects remained significant, the study established partial mediation.

### Summary of Findings

The results indicate that eco-efficiency practices significantly contribute to sustainability performance within the phosphate fertilizer industry. Energy efficiency emerged as the most influential operational driver, particularly in improving economic and environmental performance. Sustainable sourcing demonstrated a strong positive relationship with social performance.

Technological adoption showed significant positive effects on environmental, economic, and social performance and acted as an important enabling mechanism between eco-efficiency practices and sustainability outcomes. The findings highlight that sustainability performance in the fertilizer industry is strengthened when operational eco-efficiency initiatives are supported by technological capability and digital systems.

### Discussion

The findings of the study provide strong empirical support for the relationship between eco-efficiency practices, technological adoption, and sustainability performance in the phosphate fertilizer industry. The results indicate that eco-efficiency dimensions significantly influence environmental, economic, and social performance both directly and indirectly through technological adoption. These findings reinforce the growing argument in sustainability literature that operational efficiency and environmental responsibility can complement each other rather than function as competing objectives.

Among the eco-efficiency dimensions, energy efficiency emerged as the most influential factor affecting both technological adoption and economic performance. This finding is consistent with earlier studies suggesting that energy-efficient operations reduce production costs, improve operational effectiveness, and enhance sustainability outcomes (Porter & van der Linde, 1995). In energy-intensive industries such as fertilizer production,

improvements in energy utilization significantly influence both environmental and financial performance. The strong relationship between energy efficiency and technological adoption also indicates that firms increasingly depend on digital and automated systems to optimize energy management and operational control.

The results further reveal that process optimization and waste management positively influence environmental performance. Efficient operational processes reduce material losses, resource wastage, and environmental burden, thereby improving sustainability outcomes. Similarly, waste management practices contribute to pollution reduction and environmentally responsible production systems. These findings support eco-efficiency literature emphasizing the importance of preventive operational strategies in achieving industrial sustainability (DeSimone & Popoff, 1997).

Sustainable sourcing demonstrated a strong positive relationship with social performance. This suggests that responsible procurement and sustainable supply chain practices contribute significantly to stakeholder trust, ethical responsibility, and organizational sustainability orientation. In recent years, sustainability concerns have increasingly extended beyond internal operations to include supply chain accountability and supplier sustainability practices.

One of the most important findings of the study is the mediating role of technological adoption. The results indicate that technological adoption significantly enhances the effectiveness of eco-efficiency practices in improving sustainability performance. Organizations adopting advanced technologies such as automation systems, digital monitoring, predictive analytics, and process optimization tools appear better positioned to achieve environmental and operational sustainability goals. This finding supports the Resource-Based View, which considers technological capability as a strategic organizational resource contributing to performance and competitiveness (Barney, 1991).

The mediation results indicate partial mediation, suggesting that eco-efficiency practices influence sustainability performance both directly and through

technological capability. This implies that operational eco-efficiency alone may not be sufficient to achieve optimal sustainability outcomes unless supported by technological systems and digital infrastructure.

Overall, the findings highlight that sustainability performance in the phosphate fertilizer industry depends on the integration of:

- operational efficiency,
- technological capability,
- and sustainability-oriented management practices.

The study therefore strengthens the argument that eco-efficiency and technological adoption jointly contribute to sustainable industrial development.

## **Theoretical and Managerial Implications**

### **Theoretical Implications**

The study contributes to sustainability and industrial management literature in several important ways. First, it extends eco-efficiency literature by conceptualizing eco-efficiency as a multidimensional construct consisting of process optimization, waste management, energy efficiency, and sustainable sourcing. Previous studies often treated eco-efficiency as a single aggregated concept, whereas the present study demonstrates that different operational dimensions influence sustainability performance differently.

Second, the study strengthens the application of the Triple Bottom Line framework by examining sustainability performance across environmental, economic, and social dimensions simultaneously. The findings suggest that sustainability performance should be viewed as a multidimensional outcome influenced by both operational and technological capabilities.

Third, the study contributes to the Resource-Based View by establishing technological adoption as a strategic organizational capability that enhances sustainability performance. The findings indicate that technological systems function as enabling mechanisms that strengthen the impact of eco-efficiency practices on organizational outcomes.

Finally, the study contributes to mediation-based

sustainability research by empirically validating the mediating role of technological adoption. The findings help explain how eco-efficiency practices translate into sustainability outcomes within resource-intensive industrial environments.

### **Managerial Implications**

The findings provide several practical implications for managers and decision-makers within the fertilizer industry. First, the study highlights the importance of integrating eco-efficiency practices into operational strategy. Organizations focusing on process optimization, waste reduction, energy management, and sustainable sourcing are more likely to improve sustainability performance and operational effectiveness.

Second, the findings emphasize the strategic role of technological adoption in sustainability management. Firms investing in automation, digital monitoring systems, energy management technologies, and process analytics may achieve stronger sustainability outcomes compared to organizations relying solely on traditional operational practices.

Third, the strong influence of energy efficiency on economic performance suggests that managers should prioritize energy optimization initiatives to reduce operational costs and improve productivity. Similarly, sustainable sourcing practices may strengthen stakeholder relationships and improve organizational reputation.

The findings also indicate that sustainability initiatives should not be viewed merely as regulatory obligations. Instead, sustainability-oriented operational strategies may contribute to:

- long-term competitiveness,
- operational resilience,
- and organizational performance.

Overall, the study suggests that sustainable industrial performance requires alignment between:

- operational eco-efficiency,
- technological capability,
- and sustainability-oriented strategic decision-making.

## Conclusion

The present study examined the relationship between eco-efficiency practices, technological adoption, and sustainability performance in the phosphate fertilizer industry. The study conceptualized eco-efficiency through four operational dimensions:

- process optimization,
- waste management,
- energy efficiency,
- and sustainable sourcing.

Sustainability performance was examined across environmental, economic, and social dimensions, while technological adoption was analyzed as a mediating variable.

The findings revealed that eco-efficiency practices significantly influence sustainability performance both directly and indirectly through technological adoption. Among the operational dimensions, energy efficiency emerged as the strongest contributor to economic and environmental performance, while sustainable sourcing significantly influenced social performance. Technological adoption demonstrated significant positive effects on all dimensions of sustainability performance and partially mediated the relationship between eco-efficiency practices and sustainability outcomes.

The study concludes that sustainable performance in the phosphate fertilizer industry is strengthened when operational eco-efficiency practices are supported by technological systems and digital capabilities. The findings reinforce the importance of integrating sustainability initiatives with technological advancement and operational efficiency.

Overall, the study contributes to sustainability literature by providing an integrated framework linking eco-efficiency, technological adoption, and sustainability performance within a resource-intensive industrial context. The findings may assist managers, policymakers, and researchers in promoting more sustainable and technology-enabled industrial systems.

## References

- Ahi, P., & Searcy, C. (2013). A comparative literature analysis of definitions for green and sustainable supply chain management. *Journal of Cleaner Production*, 52, 329–341.
- Barney, J. (1991). Firm resources and sustained competitive advantage. *Journal of Management*, 17(1), 99–120.
- Baron, R. M., & Kenny, D. A. (1986). The moderator–mediator variable distinction in social psychological research: Conceptual, strategic, and statistical considerations. *Journal of Personality and Social Psychology*, 51(6), 1173–1182.
- Bansal, P., & Roth, K. (2000). Why companies go green: A model of ecological responsiveness. *Academy of Management Journal*, 43(4), 717–736.
- Carroll, A. B. (1991). The pyramid of corporate social responsibility: Toward the moral management of organizational stakeholders. *Business Horizons*, 34(4), 39–48.
- DeSimone, L. D., & Popoff, F. (1997). *Eco-efficiency: The business link to sustainable development*. MIT Press.
- DiMaggio, P. J., & Powell, W. W. (1983). The iron cage revisited: Institutional isomorphism and collective rationality in organizational fields. *American Sociological Review*, 48(2), 147–160.
- Dyllick, T., & Hockerts, K. (2002). Beyond the business case for corporate sustainability. *Business Strategy and the Environment*, 11(2), 130–141.
- Elkington, J. (1997). *Cannibals with forks: The triple bottom line of 21st century business*. Capstone Publishing.
- Fornell, C., & Larcker, D. F. (1981). Evaluating structural equation models with unobservable variables and measurement error. *Journal of Marketing Research*, 18(1), 39–50.
- Frosch, R. A., & Gallopoulos, N. E. (1989). Strategies for manufacturing. *Scientific American*, 261(3), 144–152.

- Gellings, C. W., & Parmenter, K. E. (2004). *Energy efficiency in industrial processes*. Fairmont Press.
- Govindan, K., Rajendran, S., Sarkis, J., & Murugesan, P. (2015). Multi criteria decision making approaches for green supplier evaluation and selection: A literature review. *Journal of Cleaner Production*, 98, 66–83.
- Hair, J. F., Black, W. C., Babin, B. J., & Anderson, R. E. (2019). *Multivariate data analysis* (8th ed.). Cengage Learning.
- Hart, S. L. (1995). A natural-resource-based view of the firm. *Academy of Management Review*, 20(4), 986–1014.
- Kline, R. B. (2016). *Principles and practice of structural equation modeling* (4th ed.). Guilford Press.
- Luthra, S., Garg, D., & Haleem, A. (2015). Critical success factors of green supply chain management for achieving sustainability in Indian automobile industry. *Production Planning & Control*, 26(5), 339–362.
- Melnyk, S. A., Sroufe, R. P., & Calantone, R. (2003). Assessing the impact of environmental management systems on corporate and environmental performance. *Journal of Operations Management*, 21(3), 329–351.
- Porter, M. E., & Kramer, M. R. (2011). Creating shared value. *Harvard Business Review*, 89(1–2), 62–77.
- Porter, M. E., & van der Linde, C. (1995). Toward a new conception of the environment-competitiveness relationship. *Journal of Economic Perspectives*, 9(4), 97–118.
- Rao, P., & Holt, D. (2005). Do green supply chains lead to competitiveness and economic performance? *International Journal of Operations & Production Management*, 25(9), 898–916.
- Saunders, M., Lewis, P., & Thornhill, A. (2019). *Research methods for business students* (8th ed.). Pearson Education.
- Schaltegger, S., & Burritt, R. (2017). *Contemporary environmental accounting: Issues, concepts and practice*. Routledge.
- Seuring, S., & Müller, M. (2008). From a literature review to a conceptual framework for sustainable supply chain management. *Journal of Cleaner Production*, 16(15), 1699–1710.
- Shrivastava, P. (1995). Environmental technologies and competitive advantage. *Strategic Management Journal*, 16(S1), 183–200.
- Teece, D. J., Pisano, G., & Shuen, A. (1997). Dynamic capabilities and strategic management. *Strategic Management Journal*, 18(7), 509–533.
- WCED (World Commission on Environment and Development). (1987). *Our common future*. Oxford University Press.
- Womack, J. P., & Jones, D. T. (1996). *Lean thinking: Banish waste and create wealth in your corporation*. Simon & Schuster.
- World Business Council for Sustainable Development. (2000). *Eco-efficiency: Creating more value with less impact*. WBCSD.